

DSp



INTENDED USE

The DSP Destratifier is used to alleviate the heat stratification problems and to move the heat generated by local heat sources in any space from the ceiling to the floor. For best efficiency, they are recommended for spaces of ceiling heights up to 6 m.

UNIT DESCRIPTION

The DSP Destratifier is available in two sizes.

They incorporate:

- axial-flow fan
- housing with confusor to increase the air blow, made of ABS
- fan on/off thermostat control

WORKING CONDITIONS

The DSP destratifier works intermittently, its switching on and off being controlled by the thermostat situated by the blower and preset to the temperature 5 - 10°C higher than the temperature of the area where men work.

The size and quantity of the destratifiers needed should be selected so that the air blowing range corresponds to ceiling height while the total air flow is between one and two volumes of the space.

DESIGNATIONS

Destratifier

DSp - 1

Unit size

1, 2

TECHNICAL DATA

Basic dimensions

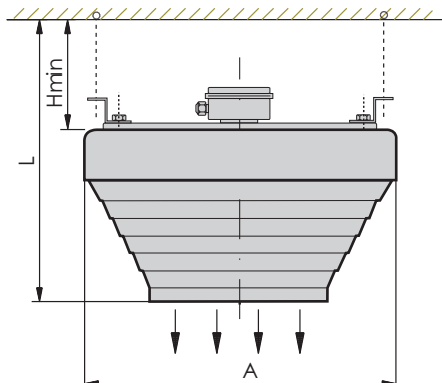

| Size | Air flow [m ³ /h] | Motor power [kW] | Current [A] | Voltage [V] | A [mm] | L [mm] | H [mm] | Weight [kg] |
|-------|------------------------------|------------------|-------------|-------------|--------|--------|--------|-------------|
| DSp-1 | 1850 | 0,13 | 0,59 | 230 | 446 | 445 | 200 | 7 |
| DSp-2 | 5400 | 0,61 | 0,61 | 230 | 620 | 585 | 250 | 14 |

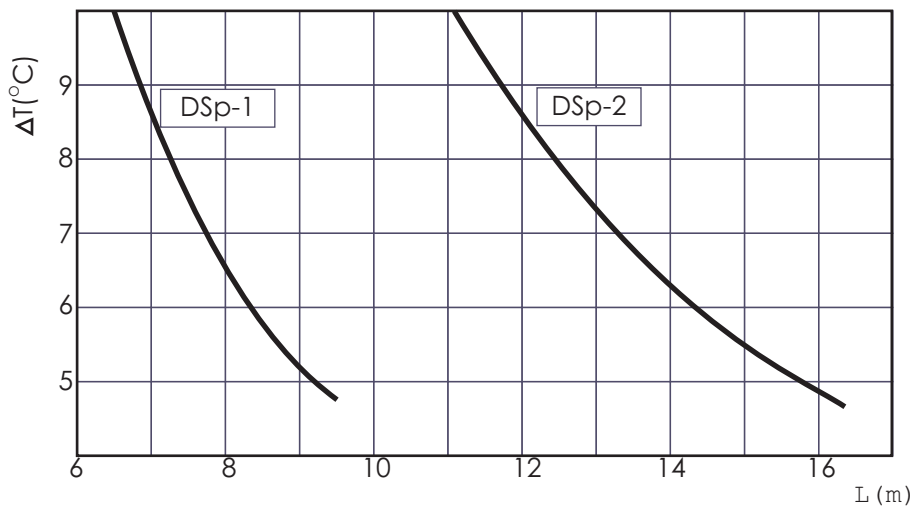

L - air blowing range vertically down
 ΔT - air temperature differential between ceiling and floor levels

| Size | Noise level [dB(A)] | | |
|-------|---------------------|---------------------|---------------------|
| | A=100m ² | A=300m ² | A=500m ² |
| | From distance of 5m | | |
| DSp-1 | 54 | 50 | 49 |
| DSp-2 | 63 | 59 | 58 |

*Level of noise level of acoustic pressure with room absorbing capabilities A=100m²; A=300m²; A=500m² and directivity factor Q=2 taken into account.