

RGS RECUPERATORS

SIZES 250 ÷ 2000
250 - 2000m³/h

MAIN FUNCTIONS OF AIR PROCESSING

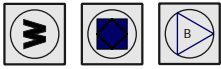

OPTIONAL FUNCTIONS OF AIR PROCESSING

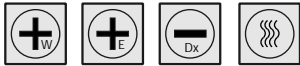

AIR CAPACITY RANGE

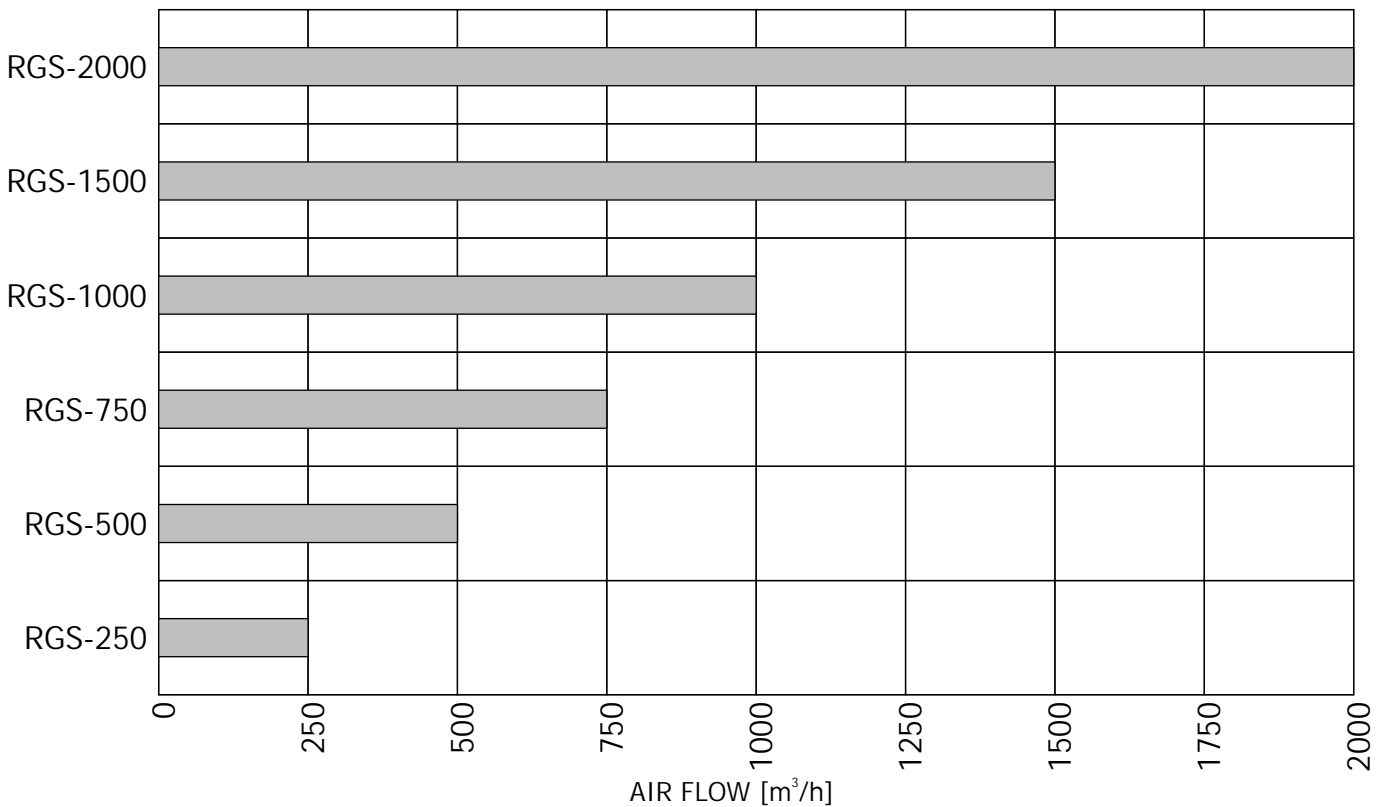

DESIGNATIONS

RGS - [] - [] - [] / [] / [] / []

SIZE

250, 500, 750, 1000, 1500, 2000

TYPE

V - inlets and outlets directed vertically, H - inlets and outlets directed horizontally

SERVICE SIDE

P - right, L - left

HEATER (optional equipment) *

NLWP - water right, NLWL - water left NEP - electric right, NEL - electric left

COOLER (optional equipment) *

CFP - right freon cooler, CFL - left freon cooler,

AUTOMATICS

AWK1, AWK2, AWK3, AWK4, AWK5, AWK6

* -installed on ventilation ducts.

CHARACTERISTICS OF THE FANS

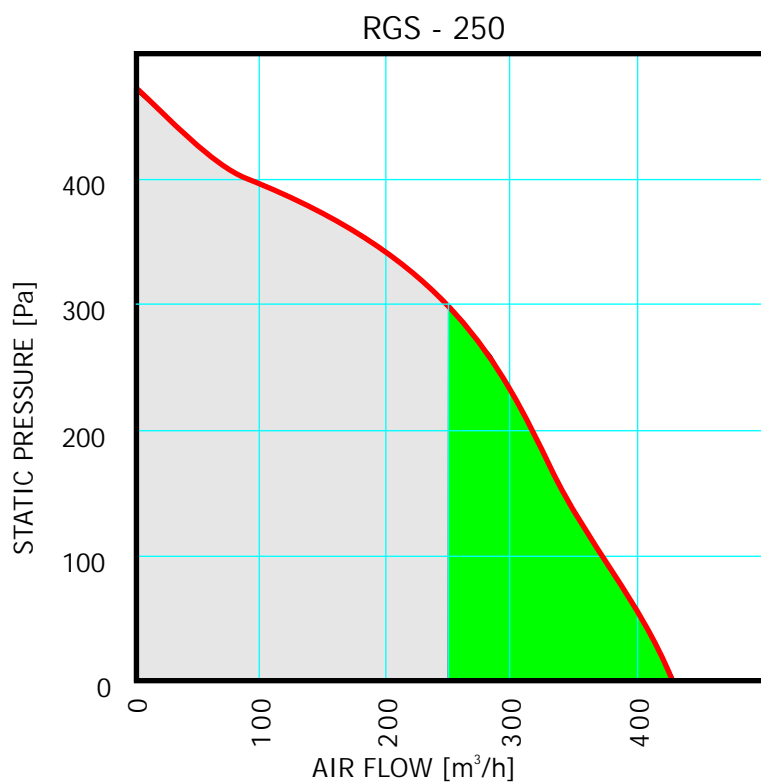

- nominal voltage 230 V
- frequency 50/60 Hz
- max rotational velocity 4480 rpm
- max. power consumption 52 W
- max. current consumption 0,40 A
- min. working temperature -25 °C
- max. working temperature +60 °C
- protection class IP 44
- min. acoustic pressure 40 dB (A)
- max. acoustic level 60 dB (A)

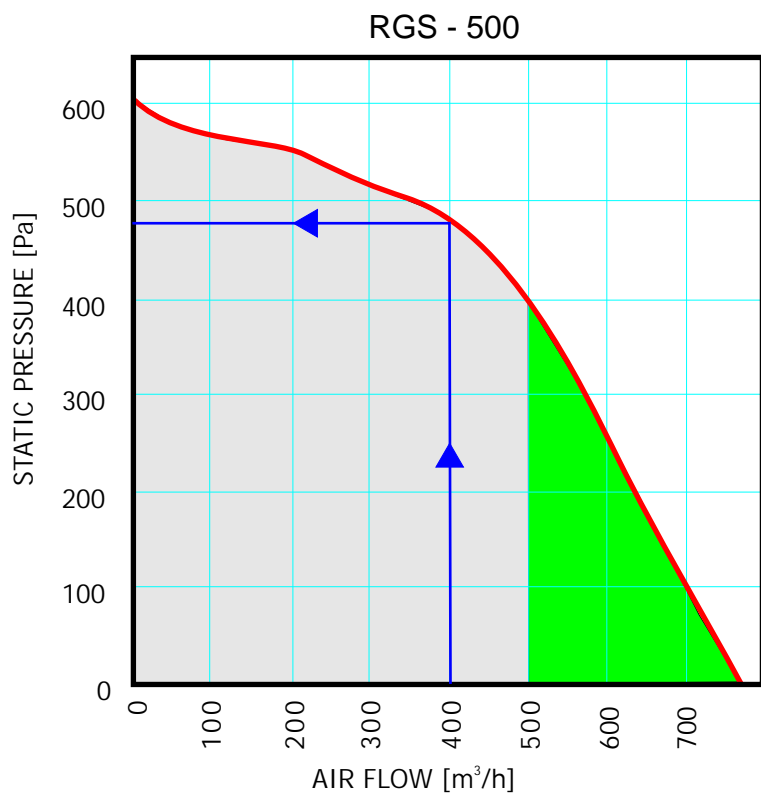

- nominal voltage 230 V
- frequency 50/60 Hz
- max. rotational velocity 4460 rpm
- max. power consumption 120 W
- max. current consumption 1,00 A
- min. working temperature -25 °C
- max. working temperature +60 °C
- protection class IP 44
- min. acoustic pressure 33 dB (A)
- max. acoustic pressure 66 dB (A)

- recommended working area

- max. working area

CHARACTERISTICS OF THE FANS

RGS - 750

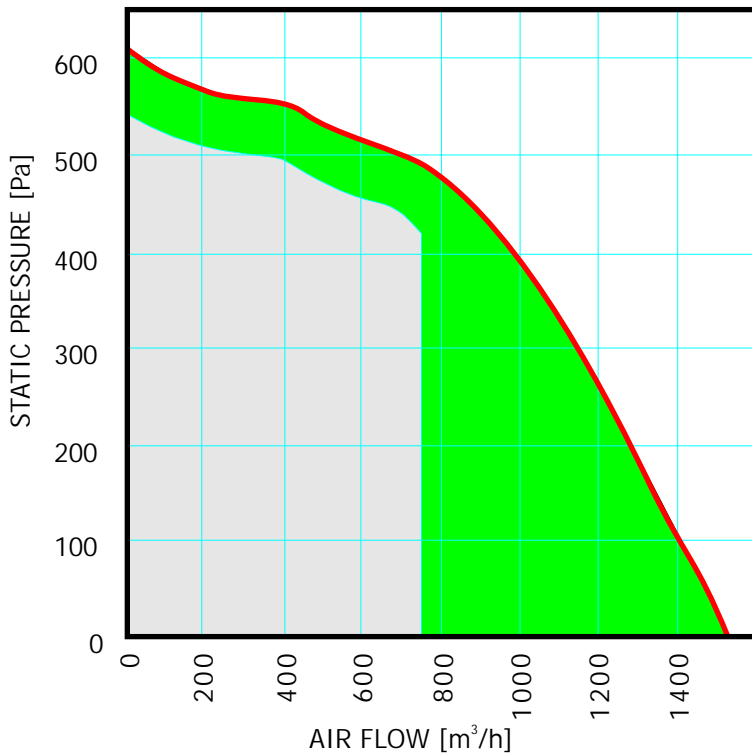

- nominal voltage 230 V
- frequency 50/60 Hz
- max. rotational velocity 4480 rpm
- max. power consumption 2x52 W
- max. current consumption 2x0,40 A
- min. working temperature -25 °C
- max. working temperature +60 °C
- protection class IP 44
- min. acoustic pressure 40 dB (A)
- max. acoustic pressure 60 dB (A)

RGS - 1000

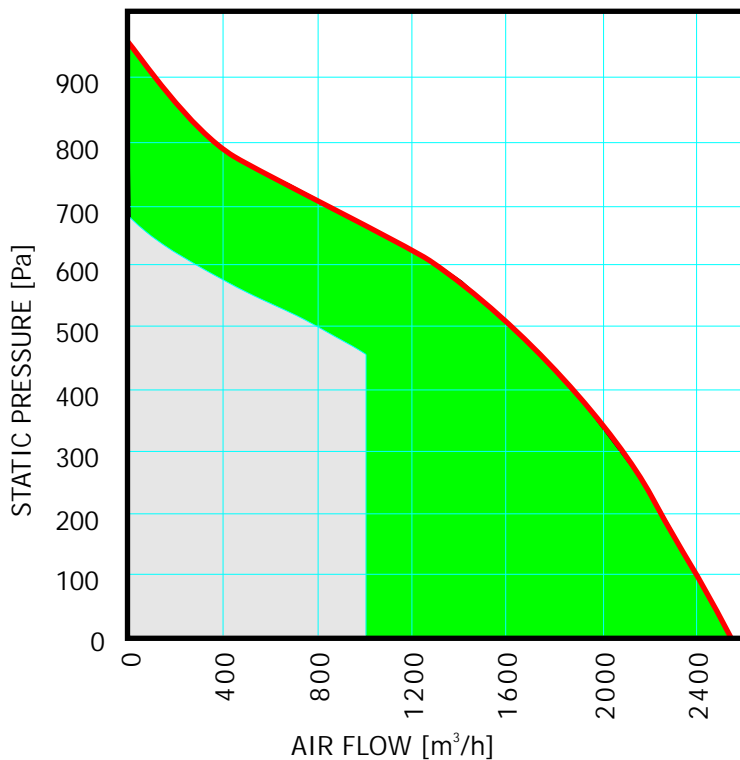

- nominal voltage 230 V
- frequency 50/60 Hz
- max. rotational velocity 2920 rpm
- max. power consumption 420 W
- max. current consumption 2,50 A
- min. working temperature -25 °C
- max working temperature +60 °C
- protection class IP 54
- min. acoustic pressure 60 dB (A)
- max acoustic pressure 73 dB (A)

 - recommended working area

 - max. working area

CHARACTERISTICS OF THE FANS

RGS - 1500

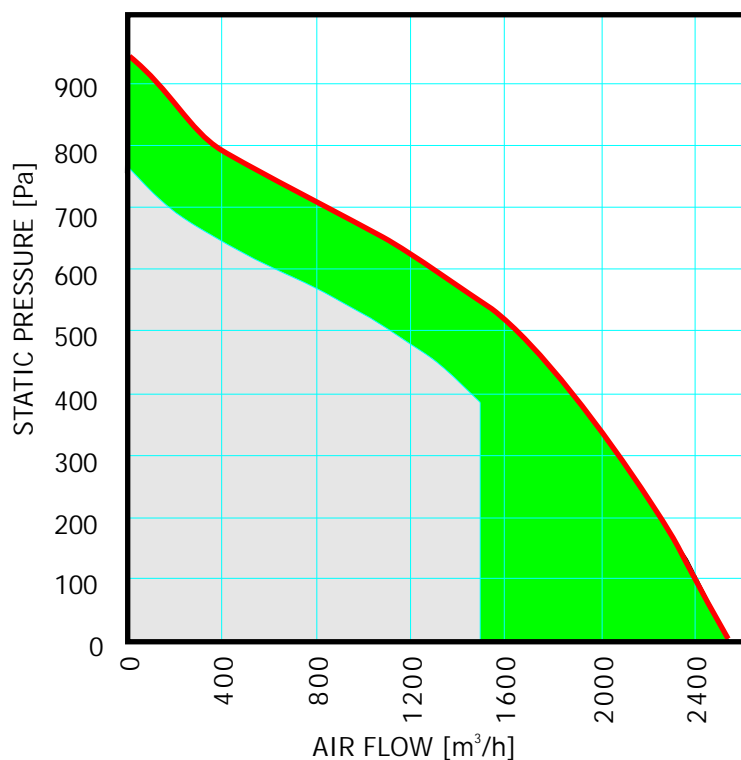

- nominal voltage 230 V
- frequency 50/60 Hz
- max. rotational velocity 2920 rpm
- max. power consumption 420 W
- max. current consumption 2,50 A
- min. operational temperature -25 °C
- max. operational temperature +60 °C
- protection class IP 54
- min. acoustic pressure 60 dB (A)
- max. acoustic pressure 73 dB (A)

RGS - 2000

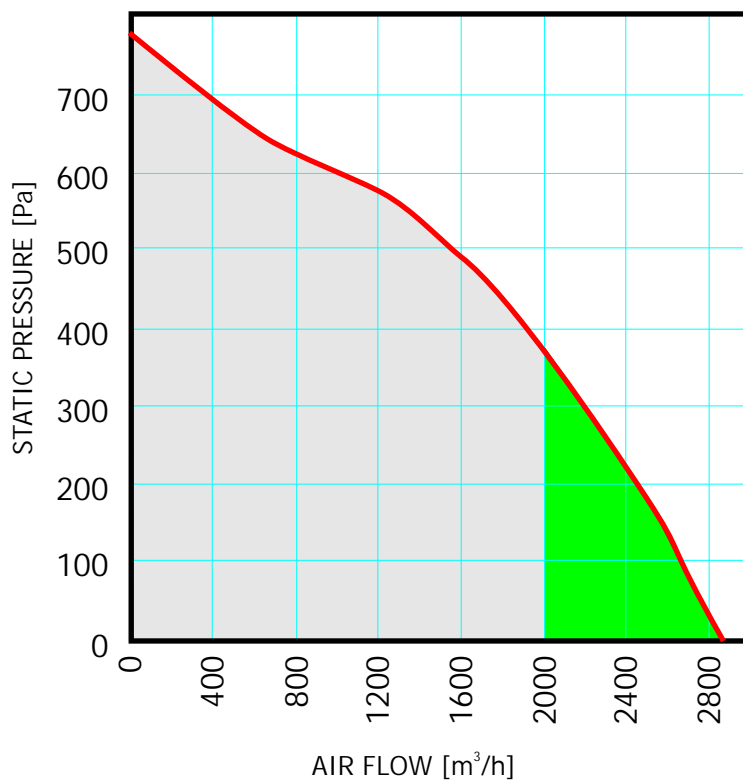

- nominal voltage 230 V
- frequency 50/60 Hz
- max. rotational velocity 2290 rpm
- max. power consumption 390 W
- max. current consumption 2,30 A
- min. working temperature -25 °C
- max. working temperature +60 °C
- protection class IP 54
- min. acoustic pressure 56 dB (A)
- max. acoustic pressure 73 dB (A)

 - recommended working area

 - max. working area

PRESSURE DROP CHARACTERISTICS OF HEAT EXCHANGERS

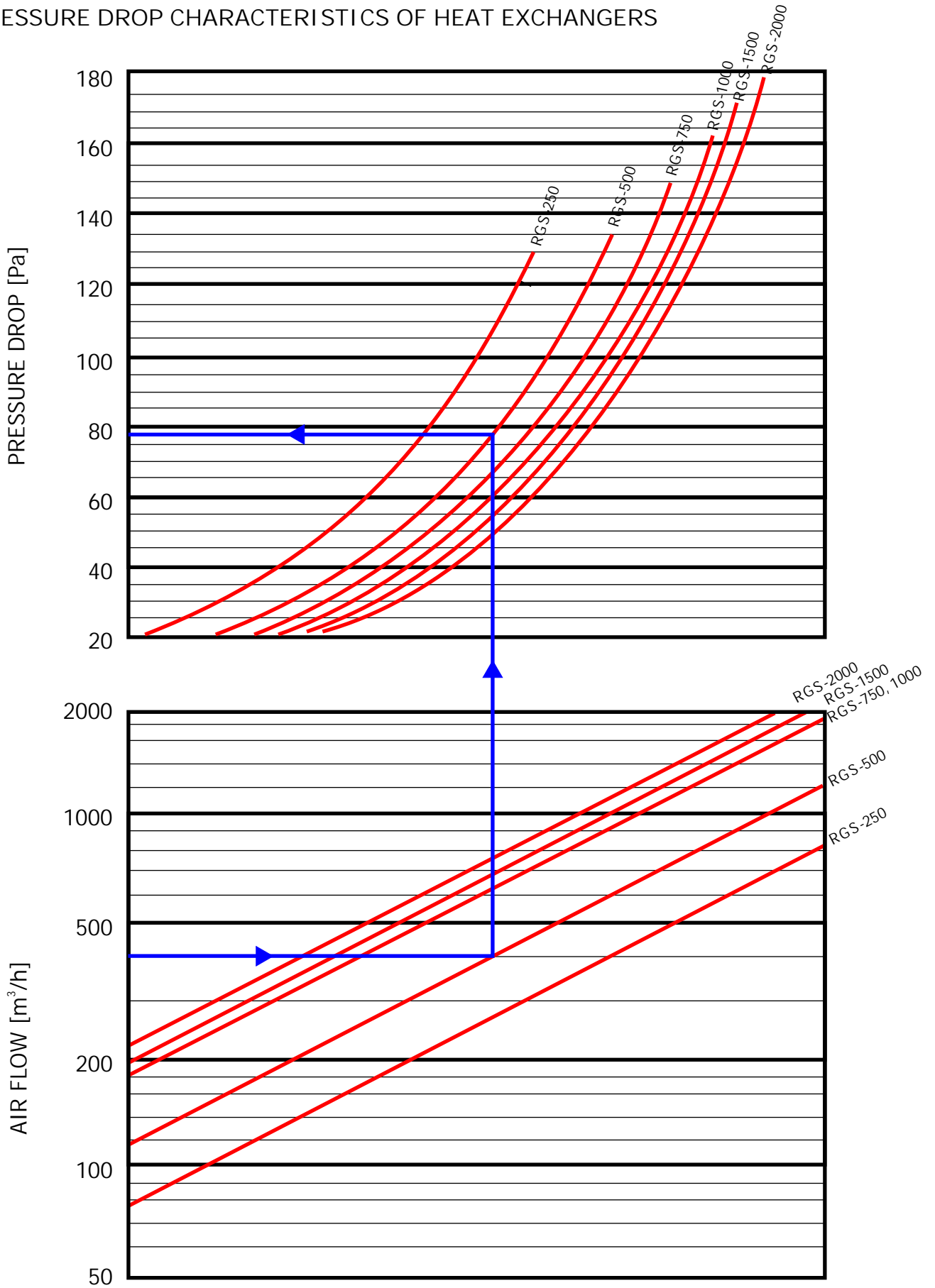

CALCULATION OF DISPOSABLE COMPRESSION

Disposable compression is calculated on the basis of attached fan characteristics, resistances of counter-current heat exchangers and filters resistances. Regarding the very small clean filters resistance (max. 10 Pa) for calculations is accepted the value of filter contamination according to the standard PN-EN 1886 which is 75 Pa. Disposable compression is calculated on the basis of following formula:

$$Pdys = 0,95 \times (Pstw - Rwp - 75) \text{ [Pa]}$$

where:

- Pdys – disposable compression of the device [Pa]
- Pstw – fan static pressure [Pa]
- Rwp – counter-current exchanger resistances [Pa]
- Rf – filter resistances [Pa]

EXAMPLE:

- air flow 400³m /h
- chosen device RGS - 500
- On RGS-500 fan characteristics we read the static pressure value (Pstw) for the air flow 400³m /h, which for maximal rotational fan velocity is 480Pa. Then, on the counter-current exchanger resistance characteristic we can read the resistance for given air flow which is 78 Pa. If we calculate according to the above formula we receive:

$$Pdys = 0,95 \times (480 - 78 - 75)$$

$$Pdys = 310 \text{ Pa}$$

CHARACTERISTICS OF EXCHANGERS EFFICIENCY

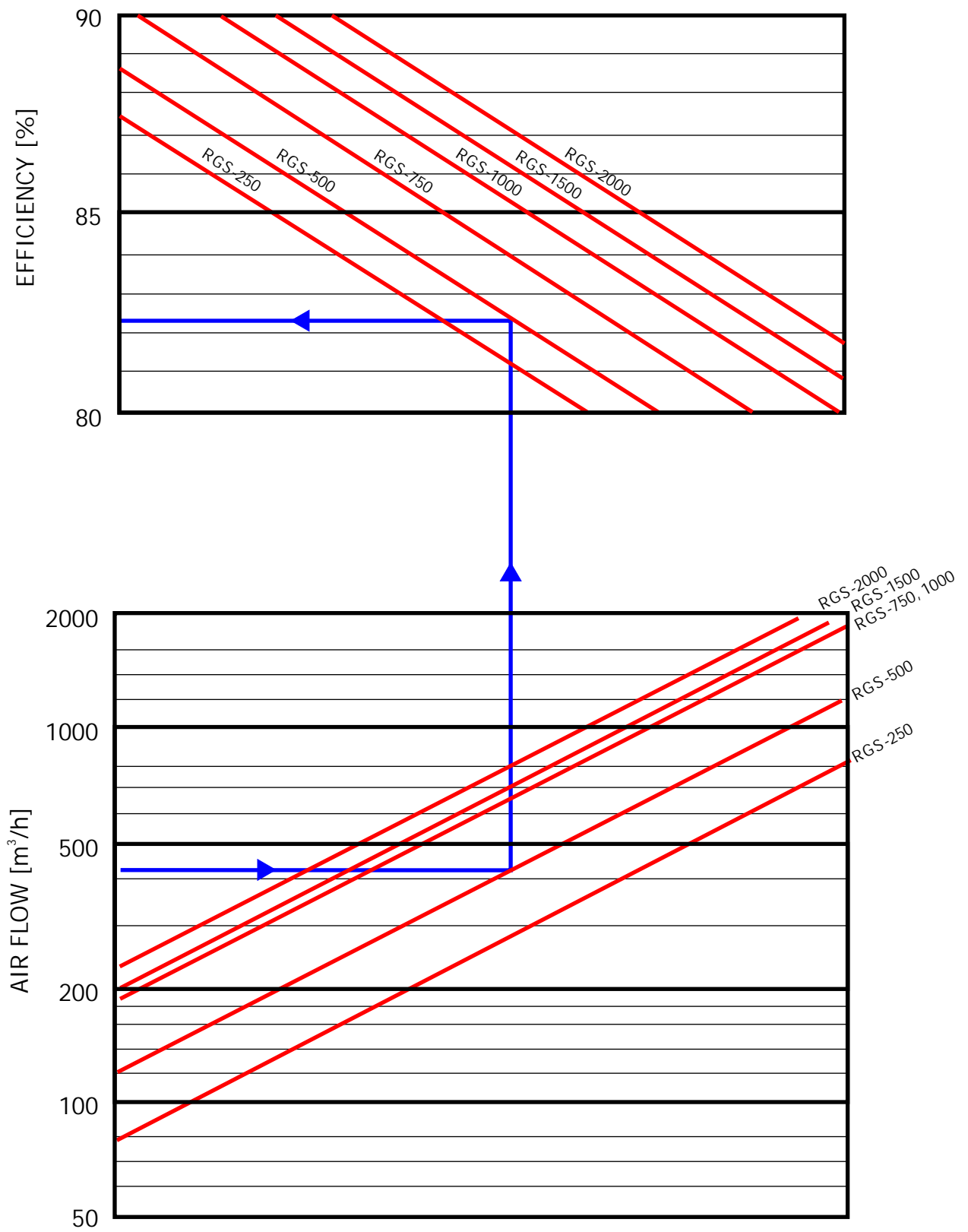

SUPPLY AIR TEMPERATURE CALCULATION

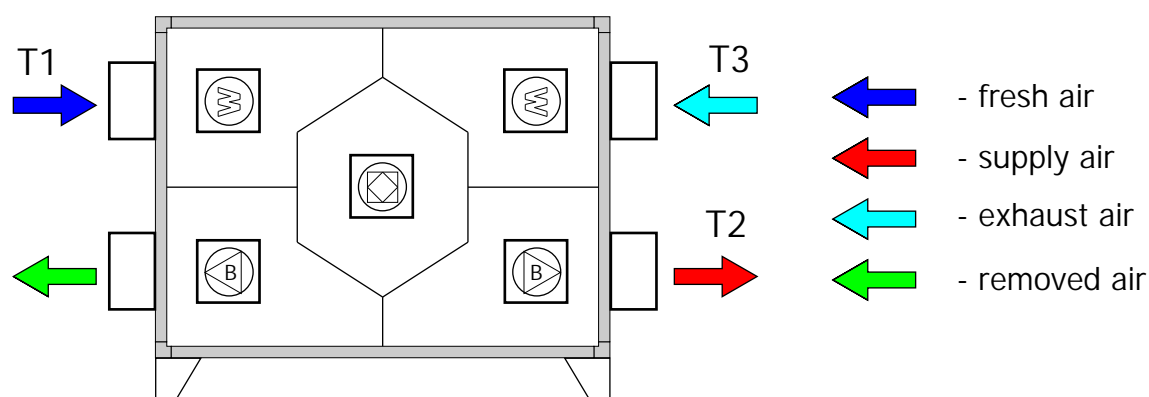

Supply air temperature is calculated according to the following formula:

$$T2 = T1 + \eta (T3 - T1)$$

where:

T1 - fresh air temperature [°C]

T2 - supply air temperature [°C]

T3 - exhaust air temperature [°C]

η - temperature efficiency of exchanger [%]

EXAMPLE:

- air flow 400m³/h

- fresh air temperature T1 = -10°C

- exhaust air temperature T3 = +20°C

- chosen device size RGS-500

Basing on the graph showed on the previous page we can see that temperature efficiency is 82,5%. After using this formula we receive:

$$T2 = -10 + 0,825 \times (20 - (-10))$$

$$T2 = 14,8 \text{ °C}$$

RGS RECUPERATORS

OVERALL DIMENSIONS

TYP - H

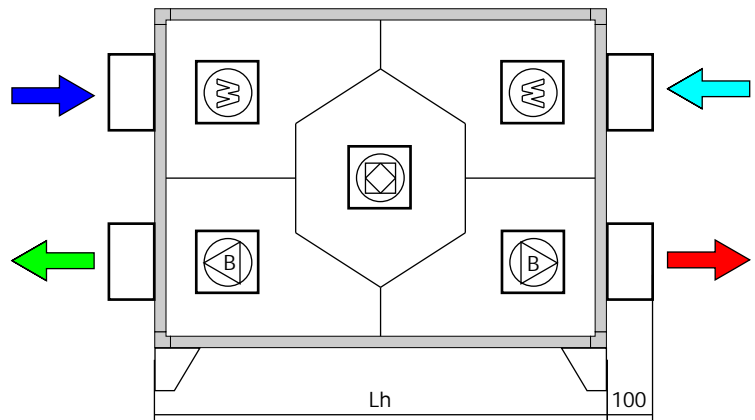
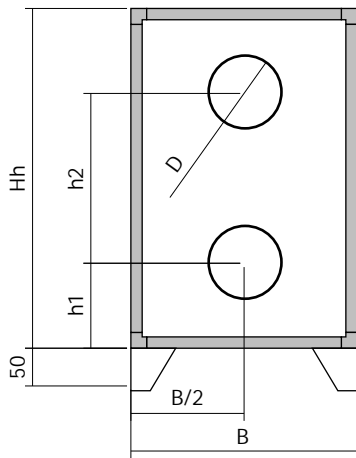

TYP - V

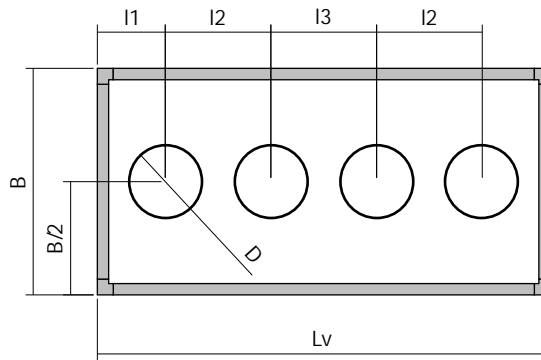
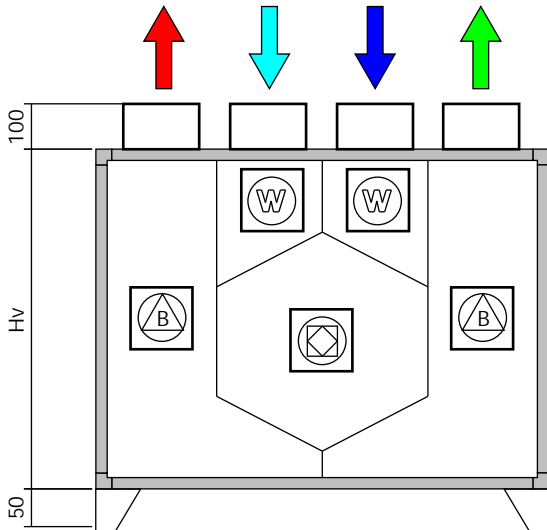

- fresh air
- exhaust air
- supply air
- removed air

		DIMENSIONS					
Size		250	500	750	1000	1500	2000
B	[mm]	400	540	750	750	780	980
Hh		650	730	870	1010	1150	1300
Lh		750	850	1000	1330	1500	1800
h1		175	195	235	265	305	340
h2		300	340	400	480	540	620
Hv		580	650	810	950	1080	1230
Lv		1050	1220	1430	1760	1900	2100
l1		150	175	195	225	240	240
l2		225	275	320	430	440	500
l3		300	320	400	450	540	620
D		160	200	225	250	315	315x315
Weight H	[kg]	45	60	92	138	170	240
Weight V		50	65	105	153	182	260

ADDITIONAL EQUIPMENT WATER HEATER

TECHNICAL DATA

RGS	250	500	750	1000	1500	2000
B	340	430	430	470	470	520
H	390	430	470	470	550	630
L	200	200	200	200	200	200
D	160	200	225	250	315	315x315
M	25	25	25	25	25	32

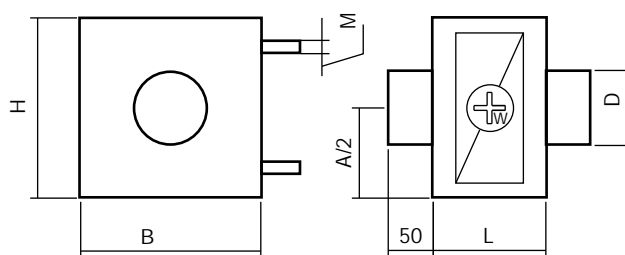

DIRECTIONS OF AIR FLOW AND HEATING MEDIUM FLOW

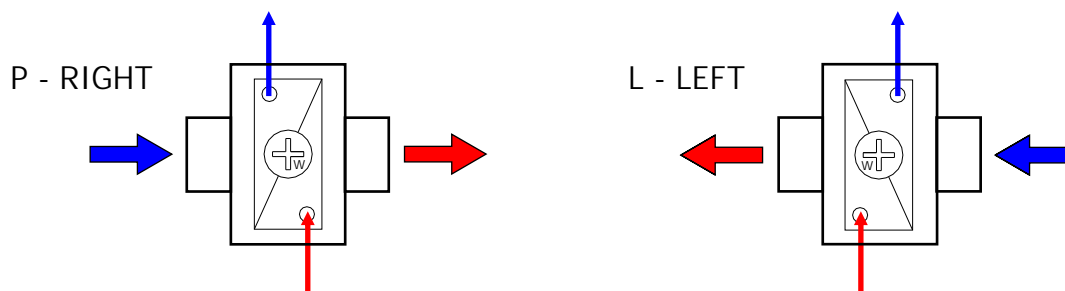

EXCHANGERS TECHNICAL PARAMETERS

HEATING WATER TEMPERATURE 80/60°C									
	Vp	T1	T2max	Qmax	Pp	Vw	Pw	V	Type
	[m³/h]	[°C]	[°C]	[kW]	[Pa]	[kg/s]	[kPa]	[dm³]	
RGS-250	250	10	40	2,5	20	0,029	0,152	0,3	NLW.G12/2,0/CA-14X32/II/2-V-P-25
RGS-500	500	10	40	5,0	35	0,060	0,268	0,5	NLW.G12/2,0/CA-22X36/II/2-V-P-25
RGS-750	750	10	40	7,5	46	0,089	1,740	0,5	NLW.G12/2,0/CA-22X40/II/2-V-P-25
RGS-1000	1000	10	40	10,0	55	0,120	3,259	0,6	NLW.G12/2,0/CA-26X40/II/2-V-P-25
RGS-1500	1500	10	40	15,0	77	0,179	11,22	1,1	NLW.G12/3,0/CA-27X48/III/3-V-P-25
RGS-2000	2000	10	40	20,0	74	0,239	7,895	1,5	NLW.G12/3,0/CA-32X56/III/3-V-P-32

HEATING WATER TEMPERATURE 70/50°C									
	Vp	T1	T2max	Qmax	Pp	Vw	Pw	V	Type
	[m³/h]	[°C]	[°C]	[kW]	[Pa]	[kg/s]	[kPa]	[dm³]	
RGS-250	250	10	31,6	1,8	20	0,021	0,084	0,3	NLW.G12/2,0/CA-14X32/II/2-V-P-25
RGS-500	500	10	32,2	3,7	26	0,044	0,152	0,5	NLW.G12/2,0/CA-22X36/II/2-V-P-25
RGS-750	750	10	33,2	5,8	46	0,069	1,081	0,5	NLW.G12/2,0/CA-22X40/II/2-V-P-25
RGS-1000	1000	10	33,5	7,8	55	0,094	2,075	0,6	NLW.G12/2,0/CA-26X40/II/2-V-P-25
RGS-1500	1500	10	34,2	12,1	77	0,145	7,587	1,1	NLW.G12/3,0/CA-27X48/III/3-V-P-25
RGS-2000	2000	10	34,1	16,1	74	0,193	5,324	1,5	NLW.G12/3,0/CA-32X56/III/3-V-P-32

HEATING WATER TEMPERATURE 60/40°C									
	Vp	T1	T2max	Qmax	Pp	Vw	Pw	V	Type
	[m³/h]	[°C]	[°C]	[kW]	[Pa]	[kg/s]	[kPa]	[dm³]	
RGS-250	250	10	23,7	1,1	20	0,014	0,036	0,3	NLW.G12/2,0/CA-14X32/II/2-V-P-25
RGS-500	500	10	24,6	2,4	26	0,029	0,070	0,5	NLW.G12/2,0/CA-22X36/II/2-V-P-25
RGS-750	750	10	26,4	4,1	46	0,049	0,568	0,5	NLW.G12/2,0/CA-22X40/II/2-V-P-25
RGS-1000	1000	10	27,0	5,7	55	0,068	1,135	0,6	NLW.G12/2,0/CA-26X40/II/2-V-P-25
RGS-1500	1500	10	28,4	9,2	77	0,110	4,538	1,1	NLW.G12/3,0/CA-27X48/III/3-V-P-25
RGS-2000	2000	10	28,2	12,2	74	0,145	3,197	1,5	NLW.G12/3,0/CA-32X56/III/3-V-P-32

ADDITIONAL EQUIPMENT ELECTRIC HEATER

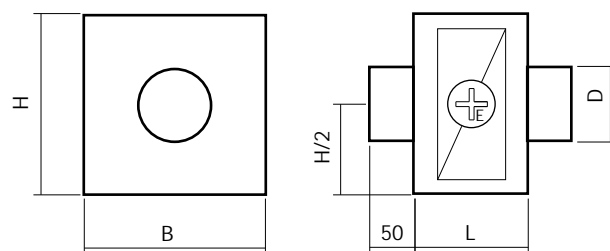

TECHNICAL DATA					
	Vp	T1	T2max	Qmax	Pp
	[m ³ /h]	[°C]	[°C]	[kW]	[Pa]
RGS-250	250	10	45	3,0	20
RGS-500	500	10	37	4,5	35
RGS-750	750	10	34	6,0	46
RGS-1000	1000	10	32	7,5	55
RGS-1500	1500	10	31	10,5	64
RGS-2000	2000	10	30	13,5	54

DIMENSIONS				
	B	H	L	D
	[mm]	[mm]	[mm]	[mm]
RGS-250	240	400	300	160
RGS-500	280	400	300	200
RGS-750	320	400	300	225
RGS-1000	360	400	300	250
RGS-1500	440	400	300	315
RGS-2000	520	400	300	315x315

ADDITIONAL EQUIPMENT FREON COOLER

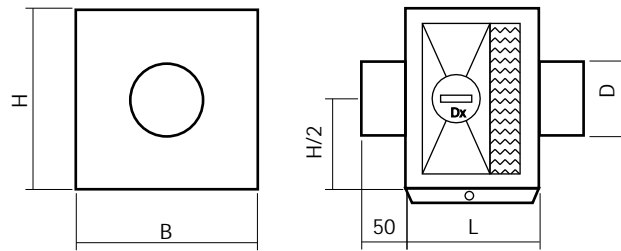

TECHNICAL DATA							
	Vp	T1		T2	Q	Pp	Type
	[m ³ /h]	[°C]	[%]	[°C]	[kW]	[Pa]	
RGS-250	250	30	45	20	1,1	25	G12/2,0/CA-14X32/II/2-V
RGS-500	500	30	45	20	2,1	32	G12/2,0/CA-22X36/III/3-V
RGS-750	750	30	45	20	3,9	82	G12/2,0/CA-22X40/III/3-V-P
RGS-1000	1000	30	45	20	4,9	101	G12/2,0/CA-26X40/III/3-V
RGS-1500	1500	30	45	20	6,8	139	G12/3,0/CA-27X48/III/3-V
RGS-2000	2000	30	45	20	9,4	132	G12/3,0/CA-32X56/III/3-V

DIMENSIONS				
	B	H	L	D
	[mm]	[mm]	[mm]	[mm]
RGS-250	340	390	400	160
RGS-500	430	430	400	200
RGS-750	430	470	400	225
RGS-1000	470	470	400	250
RGS-1500	470	550	400	315
RGS-2000	520	630	400	315x315

STORING AND TRANSPORT ON BUILDING SITE

- All the unit elements are wrapped with protective foil and put on the wooden pallets. Foil should be removed directly before the assembling.
- Device should be kept in the original packaging in the dry place out of the influence of atmospheric factors.
- Units can be transported with the help of forklift truck or crane in their normal operating position, it's necessary to pay special attention on protecting the side surfaces and protruding elements against damage.
- Before lifting the device it's necessary to make sure that the doors and inspection hatches are closed.

ASSEMBLY AND CONNECTION

- The unit should be placed on the leveled ground of a proper strength, adapted to the unit weight and size.
- It is necessary ensure the free space enabling opening all the doors and inspection hatches and to execute the standard operational activities.
- Hydraulic, electric installations etc. should be placed on such way that they don't obstruct the access to the unit.
- Minimal width which makes the filters replacing possible should be equal with unit width.
- From the service side it's necessary to plan the space which will enable replacing the internal components in the units. Space width should be equal at least the unit width + 200mm. During normal exploitation of the unit other devices and installations can be placed in this area however it's necessary to ensure the opportunity of their quick and easy disassembling.

AUTOMATICS

INTRODUCTION

Presented below automatics systems permit to achieve the reliability of operation and protections as well as the comfort with the low exploitation costs of the unit. Thank to these devices service staff task consists only in programming the required air parameters. All other functions are made by the automatic control system which adopts to the external and internal conditions. Below You can find the description of the functions and diagrams of automatic control system intended for the RGS type devices.

FUNCTIONS AND DESCRIPTION OF THEIR OPERATION

CONTROL

- Fans speed control

Automatic control system permits to simultaneous fluent speed adjustment of both fans within the range from 0 to 100. Thanks to it we can get the required air flow within the operational range of the device.

- Heating the air with water heater

In case when recuperators are equipped with water heaters the temperature adjustment in the room is made with the help of B4 exhaust air temperature sensor. If the measured value is lower than set value Mv1 servo-motor opens three-way valve and then the pump is switched on.

B2 sensor controls additionally the temperature of the air in the supply duct.

- Reheating the air with electric heater.

In case when recuperators are equipped with water heaters the temperature adjustment in the room is made with the help of exhaust air temperature sensor. If the measured value is lower than set value then control system fluently controls the heater power.

B2 sensor controls additionally the air temperature in supply duct..

- Cooling the air with freon cooler.

In case when recuperators are equipped with freon coolers temperature adjustment in the room is made with the help of exhaust air temperature sensor. If the measured value is lower than set value then cooling aggregate is switched on. Sensor B2 controls additionally the air temperature in the supply duct..

- Control of external throttling valves.

System permits to control with two servo-motors of cut-off throttling valves built in the external air duct and in the removed duct air. At the moment of switch the fans on the servo-motors operating mentioned above throttling valves are opening them. In case of voltage decay on the fans the throttling valves are closed.

SIGNALLING

- fresh air temperature measurement.

Fresh air temperature is measured by the B3 sensor. The information about the value is showed on the display.

- Supply air temperature measurement

Supply air temperature is measured by B2 sensor. Information about value is showed on the display.

- Exhaust air temperature measurement

Exhaust air temperature is measured by sensor B4. Information about value is showed on the display.

- Removed air temperature measurement

Removed air temperature is measured by B1 sensor. Information about value is showed on the display.

- Filter contamination information.

Pressure switches of F1 and F2 filters measure the pressure difference between the filters. After reaching the max. set value of 130 Pa automatics signalizes the necessity of filters replacing.

FUNCTIONS AND DESCRIPTION OF OPERATION

SIGNALLING

- Fans operation

Correct fans operations as well the failure state after activation of the overload protection are signaled on the display.

- Pump operation

Information about switching on the circulating heating water pump is shown on the display.

- Cooler operation

Information about switching on the cooling aggregate is shown on the display.

PROTECTIONS

- Water heater protection

In the RGS recuperators with water heaters as the heater protection against the freezing the anti-freeze thermostat is used. Thermostat has the capillary placed uniformly along the heater field which after the air temperature decrease (even on the short capillary section) below the threshold temperature (recommended 5°C) transfers the signal to the controller which, as the thermostat answer, signalizes the alert state, and switches the fan off, closes throttling valves of external air, totally opens heater heating water valve and switches the water pump on. The system will return to the standard working state after increase of the heater temperature.

- Protection of electric heater

In RGS recuperators with the electric heaters two-position thermostats are used which are intended to control the heater operations. Increase of heater temperature above the safe level will cause the alteration of the contact in the thermostat and adequate reaction of control system. Heater power supply is switched off and the fan is working until the temperature in the heater will fall down. Additionally heater is switched on only if we are sure that the air is flowing through it.

- Fans protection

If the motor nominal currents are exceeded then the overloading protection will be activated and the display will show information about failure state.

- Protection of the heat recovery exchanger against frosting.

B1 temperature sensor protects the heat recovery exchanger against the frosting. In case when removed air temperature behind the exchanger falls below the set value of 0°C, M1 servo/motor smoothly opens the by-pass B1 throttling valves.

AUTOMATICS FUNCTIONS COMPARISON

FUNCTIONS		Systems designations					
		AWK1	AWK2	AWK3	AWK4	AWK5	AWK6
CONTROL	Fans	+	+	+	+	+	+
	Water heater				+		+
	Electric heater			+		+	
	Freon cooler					+	+
	External throttles		+	+	+	+	+
SIGNALING	Fresh air temperature measurement		+	+	+	+	+
	Supply air temperature measurement	+	+	+	+	+	+
	Exhaust air temperature measurement	+	+	+	+	+	+
	Removed air temperature measurement		+	+	+	+	+
	Filter contamination state	+	+	+	+	+	+
	Fans operation state	+	+	+	+	+	+
	Heating water pump operation state				+		+
	Cooling aggregate operational state					+	+
PROTECTIONS	Water heater				+		+
	Electric heater			+		+	
	Fans	+	+	+	+	+	+
	Heat recovery exchanger	+	+	+	+	+	+

DESIGNATIONS AND SYMBOLS

- F1 - supply filter pressure switch
- F2 - exhaust filter pressure switch
- B1 - removed air temperature sensor
- B2 - supply air temperature sensor
- B3 - fresh air temperature sensor
- B4 - exhaust air temperature sensor
- B5 - electric heater protection thermostat
- B6 - anti-freeze thermostat
- M1 - by-pass throttling valve servo-motor
- M2* - throttling valve servo-motor on fresh air duct
- M3* - throttling valve servo-motor on removed air duct
- Mv1 - 3-way heater valve with servo-motor
- Pw* - water pump

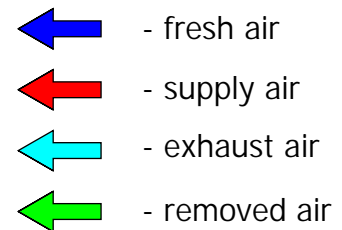

ATTENTION! Marked elements (*) are not included in delivery.

AWK1 SYSTEM DIAGRAM

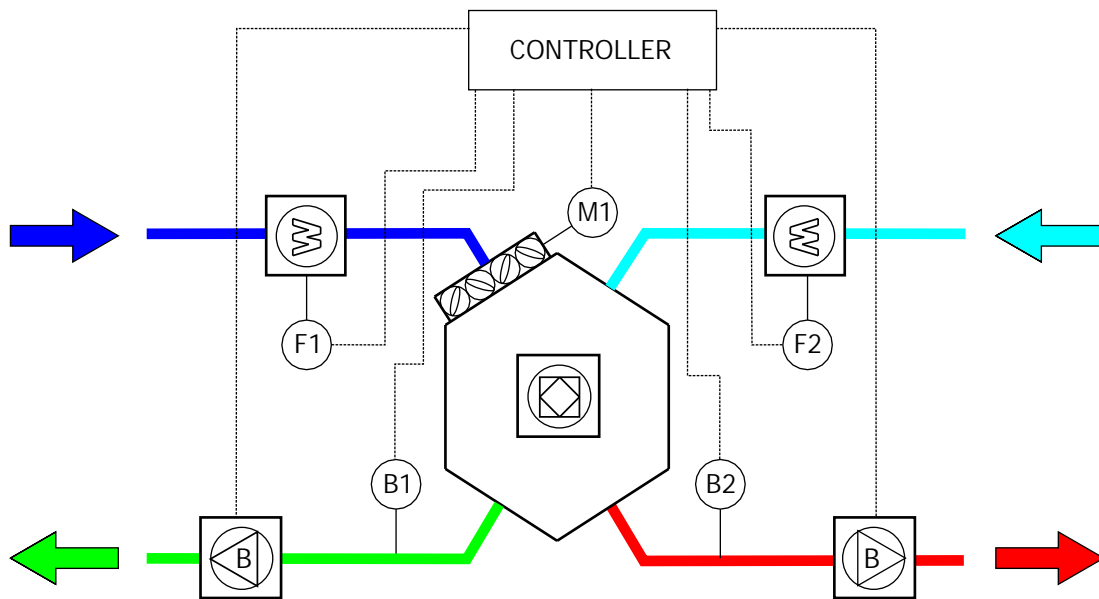

AWK2 SYSTEM DIAGRAM

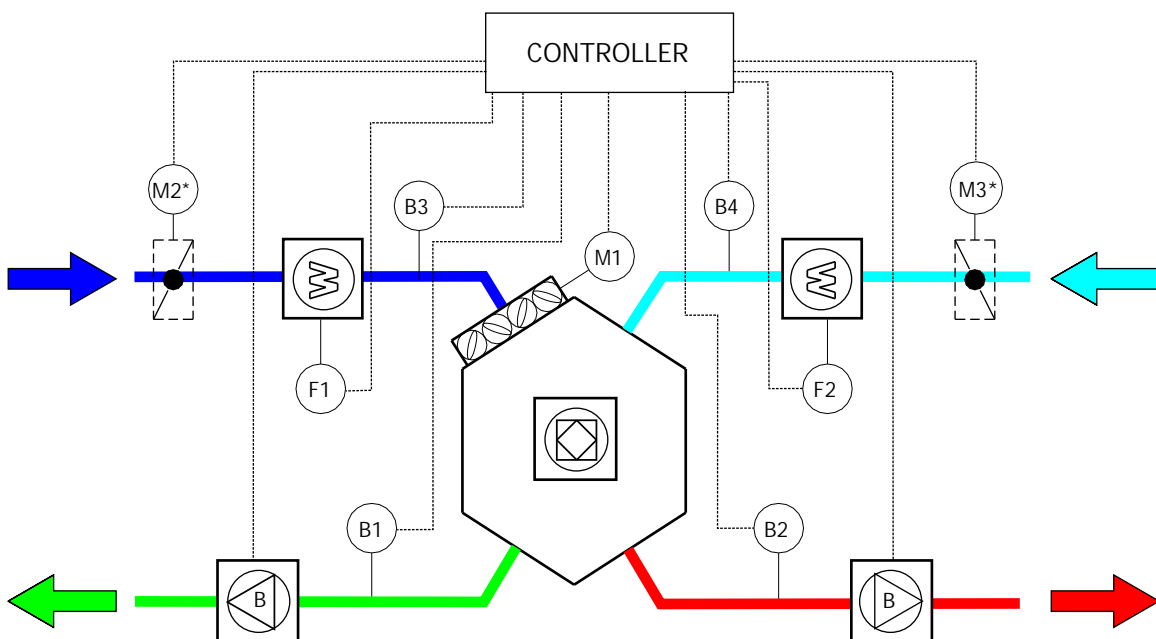

AWK2 SYSTEM DIAGRAM

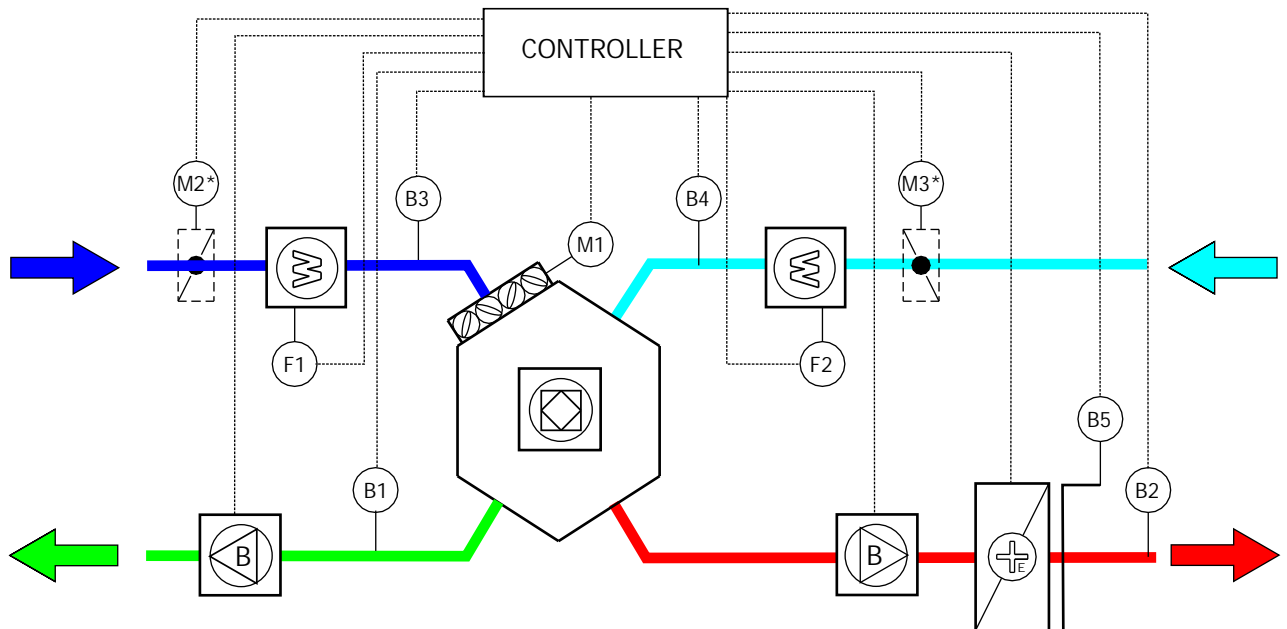

AWK4 SYSTEM DIAGRAM

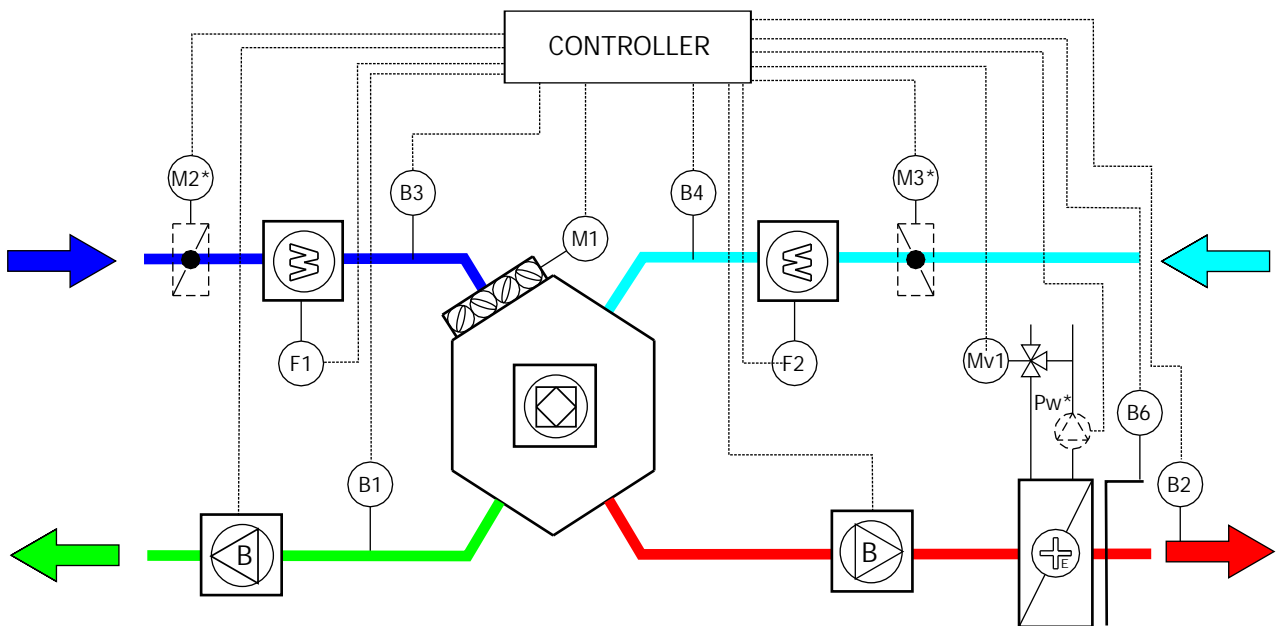

AWK5 SYSTEM DIAGRAM

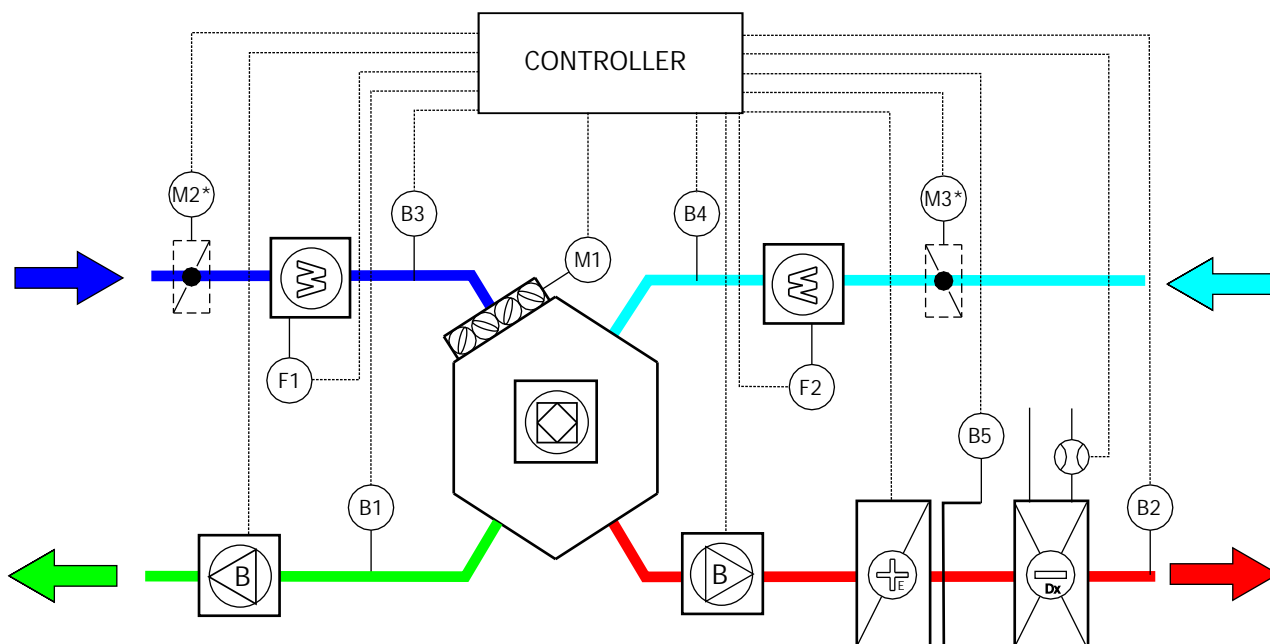

AWK6 SYSTEM DIAGRAM

