

## UGCH



### INTENDED USE

Heating and cooling units are used for heating and cooling of air in rooms such as: department stores, shops, supermarkets and in other places which needs heating in the heating period and cooling in summer.

In the unit the cooling function is dimensioning for heat exchangers. Additionally it gives the possibility of rooms heating with decreased temperature of water feeding.

The units should be placed at the max. height of 4m.

### UNIT DESCRIPTION

The units are offered in 2 sizes with one or two fans.

The unit consists of:

- metal louvre heater/cooler
- axial-flow fan
- casing
- gutters accumulating condensate

The exchangers are made of copper pipes with outer diameters of 10mm and aluminium fuses with spacing of 2mm. Connectors in standard version are with internal thread.

### WORKING CONDITIONS

Feeding of the assembly is supposed to be two-pipe, i.e. "cold" water feeding in summer and "hot" water feeding during heating period. The exchangers may operate at pressure up to 0,6 MPa.

There are tri-phase 400 V fans motors with power of 0,12kW and current input of 0,29A.

In case of cooling the condensate are carried away gravitationally via gutters under the exchangers and outlet pipes to sewage system. The units may be equipped with condensate pumps.

### DESIGNATIONS

Heating and cooling unit

UGCH - 1 - II

Size [1,2]

Number of heater rows [ II; III]

# UGCH HEATING AND COOLING UNITS

## TECHNICAL DATA

Basic dimensions

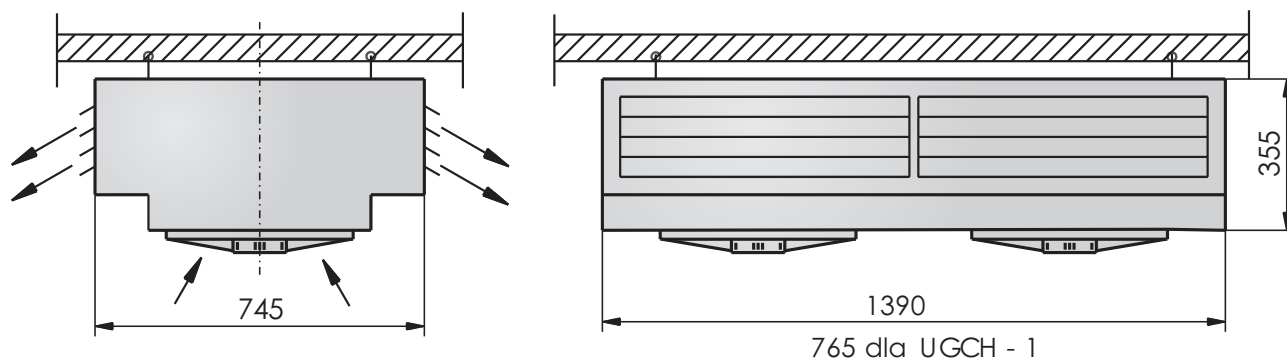

Unit size		UGCH-1				UGCH-2			
Fan type		FE 031 (1 fan)				FE 031 (2 fans)			
Air flow [m <sup>3</sup> /h]		2000				4000			
Number of heater rows		II		III		II		III	
<b>Thermal power [kW] and outflow air temperature [°C]</b>									
Water temp. [°C]	Inflow air temp. [°C]	kW	°C	kW	°C	kW	°C	kW	°C
90/70	10	28	50	34	58	58	51	74	61
	15	26	52	30	59	52	52	66	62
	20	22	54	28	60	48	54	60	63
80/60	10	24	43	28	50	48	44	61	53
	15	20	45	24	51	42	46	54	54
	20	18	47	23	52	38	47	48	55
70/50	10	18	37	22	42	38	37	50	42
	15	16	38	20	43	34	39	42	46
	20	14	40	17	45	28	41	37	47
60/40	10	14	30	18	35	30	30	38	36
	15	12	32	15	36	25	32	30	38
	20	9	35	12	37	20	34	26	39
<b>Cooling powers [kW] and outflow air temperature [°C]</b>									
Water temp. [°C]	Inflow air temp. [°C]	kW	°C	kW	°C	kW	°C	kW	°C
5/10	26	7,0	19	8,8	17	14,0	19	20,8	16
	24	5,4	18	7,2	16	10,8	18	16,0	15
	22	4,0	17	5,6	15	8,1	17	11,0	15
6/12	26	5,4	20	7,2	18	10,8	20	16,2	17
	24	4,0	19	5,6	17	8,1	19	13,0	16
	22	3,0	18	3,2	17	5,8	18	9,0	16
8/14	26	4,1	21	5,8	19	8,1	21	14,0	18
	24	2,9	20	3,6	19	5,8	20	9,2	18
	22	2,1	19	2,1	18	4,1	19	7,0	17
<b>Noise level [dB(A)]</b>									
From distance of 1m*		54				56			
From distance of 5m*		51				52			

\*Level of noise level of acoustic pressure with room absorbing capabilities  $A=50 \text{ m}^2$  and directivity factor  $Q=2$  taken into account.